

2/2-way Miniature Solenoid Valve



Type 6011 can be combined with...



Type 2506

Cable plug to
DIN EN 175301-803*
form C



Type 2507

Cable plug industrial
standard form B

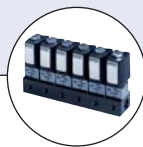

Type 6012

Multiple manifold
(e.g. 6-fold)

- Direct-acting
- 0 ... 21 bar ¹⁾
- DN 1.2 ... 2.4 mm
- M5, G1/8 and sub-base
- 21 mm coil spacing when mounted on manifold

This direct-acting 2/2-way miniature solenoid valve is available in two versions.

Standard version:

Type 6011 is a miniature solenoid valve used for shut-off, dosing, filling, ventilating and for technical vacuum. It is of modular design and may be mounted individually or as a block on a multiple manifold.

Analysis and vacuum technology:

Type 6011 A is a high-quality miniature solenoid valve for analysis and vacuum technology. It is manufactured under clean-room conditions. This includes thorough cleaning of all parts in contact with media from organic and inorganic substances. The limit for residual hydrocarbons is below 0.2 mg/dm³. 100 % of the valves are subjected to a special leakage test with regard to tight seating and tightness to the exterior. The permissible leakage rate is 10⁻⁴ mbar l/s. The valve is used for shut-off, dosing, filling, ventilating and particularly for analysis technology.

Circuit function A

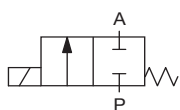

2/2-way valve,
normally closed by
spring force

Technical data	
Body material	Type 6011 Type 6011 A
	brass, polyamide (PA), stainless steel 1.4305 brass, stainless steel 1.4305
Sealing material	FKM
Analytical version (Typ 6011 A)	version free from silicones, oil and grease leaktightness better than 10 ⁻⁴ mbar l/s
Limit value for remainder carbon (Type 6011 A)	<0,2 mg/dm ³
Medium	Type 6011 Type 6011 A
	<ul style="list-style-type: none"> ▪ technical vacuum ▪ neutral gases and fluids (e.g. compressed air, water hydraulic oil ▪ neutral/aggressive media that do not attack the body and seal materials
Medium temperature	-10 ... +100 °C
Ambient temperature	max. +55 °C
Viscosity	max. 21 mm ² /s
Port connection	Type 6011 Type 6011 A
	M5, G1/8, sub-base G1/8, sub-base
Betriebsspannung	Type 6011 Type 6011 A
	24 V DC, 24 V/50 Hz, 110 / 230 V / 50 Hz 24 V DC, 230 V / 50 Hz
Voltage tolerance	± 10%
Duty cycle/single valve	when mounted as a block on a manifold
	100 % continuous rating Intermittent operation 60 % (30 min) or with 2 W coil (on request)
Electrical connection	<ul style="list-style-type: none"> ▪ to DIN EN 175301-803* Form C for cable plug Type 2506 (see Ordering chart for Accessories) ▪ Form B (industrial standard) for Type 2507 (see Ordering chart for Accessories)
Installation	as required, preferably with actuator upright
Assembly	no oil, grease or silicones to be used as installation aids
Mass	ca. 125 g
Protection class	IP65 with cable plug

¹⁾ Pressure data [bar]: Overpressure with respect to atmospheric pressure

* previously DIN 43650

Response times

Orifice [mm]	K _v value water [m ³ /h]	Pressure range		Coil power [W]	Power consumption			Response times		
		for AC [bar]	for DC [bar]		Inrush AC [VA]	Hold AC (hot coil) [VA]	[W]	DC (hot/cold coil) [W]	Opening [ms]	Closing [ms]
1.2	0.045	0-21	0-12	4 W	9	6	4	4/5.5	7-10	10-15
1.6	0.06	0-12	0-6	4 W	9	6	4	4/5.5	7-10	10-15
2.0	0.11	0-8	0-4.5	4 W	9	6	4	4/5.5	7-12	7-12
2.4	0.13	0-6	0-3	4 W	9	6	4	4/5.5	7-12	7-12

¹⁾ Pressure data [bar]: Overpressure with respect to atmospheric pressure

- k_v value [m³/h]: Flow rate value for water, measured at +20 °C and 1 bar¹⁾ pressure differential over a fully opened valve.
- Response times [ms]: measured at valve outlet at 6 bar¹⁾ and +20 °C
Opening: pressure build-up 0 ... 90 %, closing: pressure relief 100 ... 10 %

Material

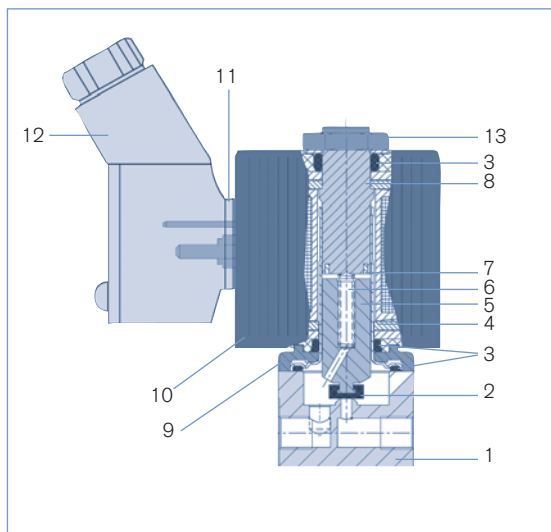

1	Body	Brass, stainless steel 1.4305 PA (polyamide)
2	Armature seal	FKM
3	O-ring	FKM
4	Guide tube	Stainless steel 1.4303
5	Core	Stainless steel 1.4105
6	Spring	Stainless steel 1.4310
7	Shading ring	Copper, Silver
8	Stopper	Stainless steel 1.4105
9	Sub-base	Thick-film passivated (brass version) nickel-plated surface (stainless steel version)
10	Coil	DIN EN 175301-803* form C Form B (industr. standard)
		PA Epoxy
11	Flat seal	NBR
12	Cable plug	PA
13	Locknut	Thick-film passivated

^{*)} bisher DIN 43650

Dimensions [mm]

Multiple manifold

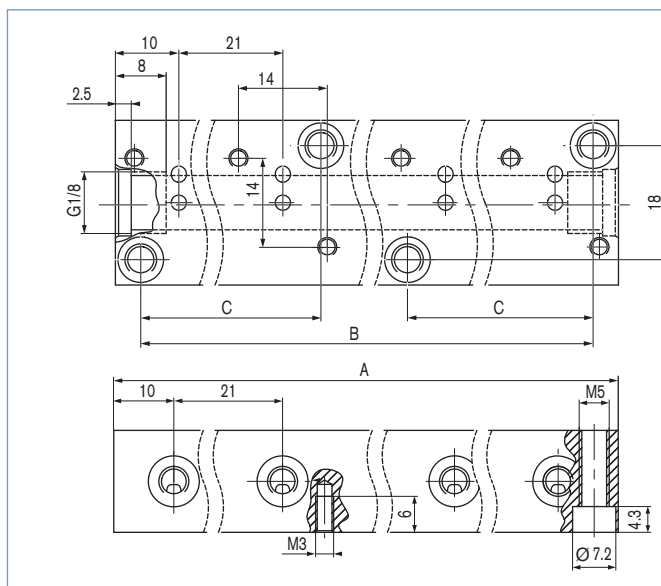

No. of valves	A [mm]	B [mm]	C [mm]
1	20	12	-
2	41	33	-
3	62	54	-
4	83	75	-
5	104	96	-
6	125	117	-
7	146	138	-
8	167	159	54
9	188	180	54
10	209	201	75
11	230	222	75
12	251	243	96

Dimensions [mm]

Single manifold

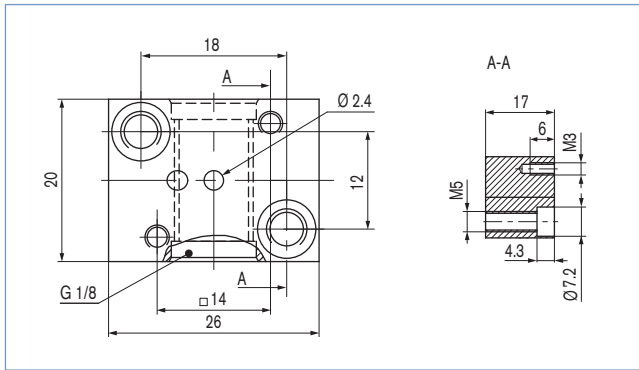

Type 6011 / 6011 A
Version with electrical coil connection
to DIN EN 175301-803* form C
(cable plug type 2506)

Type 6011 / 6011 A
Version with electrical coil connection
Form B industrial standard
(cable plug type 2507)

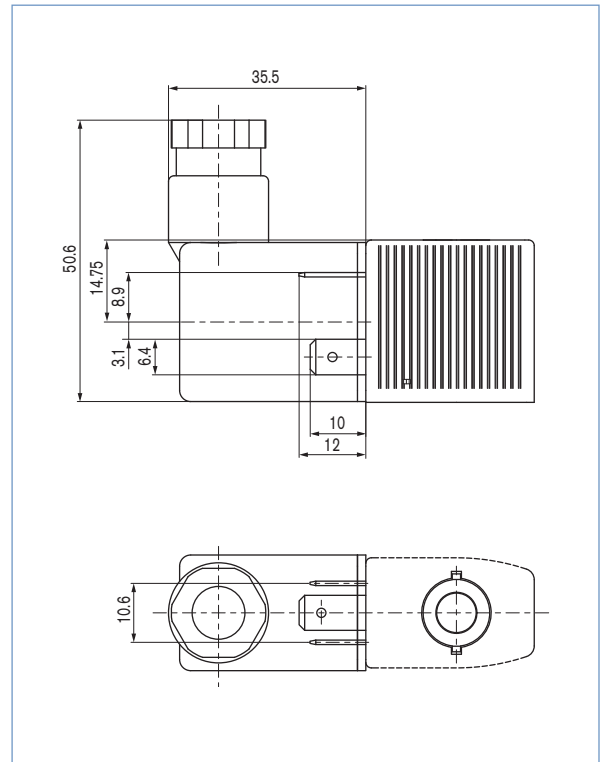
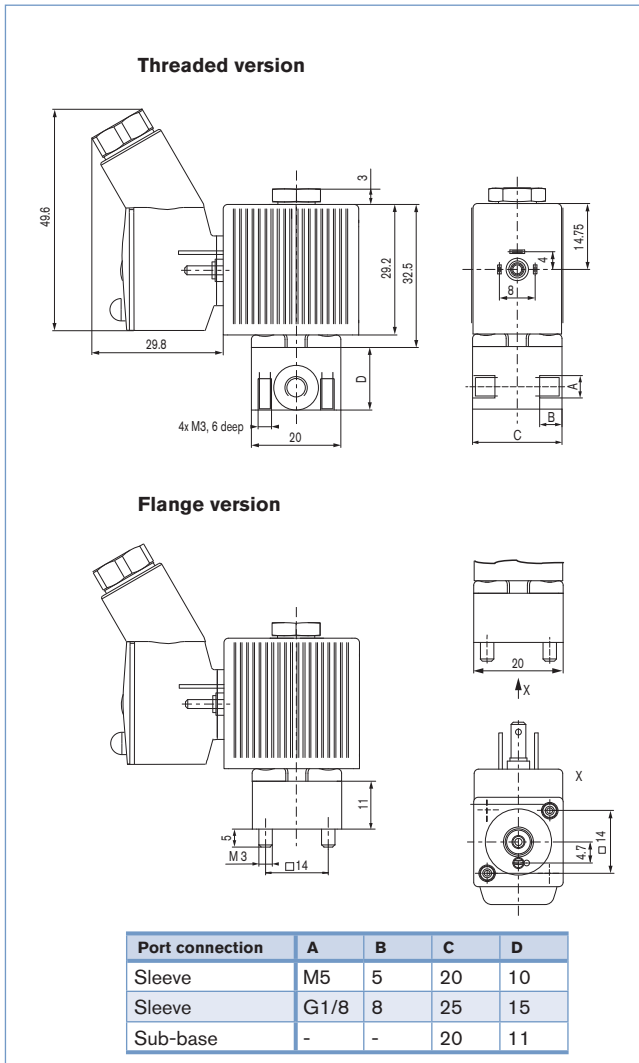

* previously DIN 43650

Ordering chart

Type 6011

Solenoid valve complete in ported or flanged version with electrical coil connection to DIN EN 175301-803* Form C for cable plug Type 2506

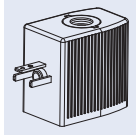

- All valves complete with coil and FKM seal material; without cable plug
- Other versions on request.

Circuit function	Orifice [mm]	Port connection	Kv value water [m ³ /h]	Pressure range [bar] ¹⁾	Voltage/Frequency [V/Hz]	Item no. Brass body	Item no. Stainless steel body
A 	1.2	M5	0.045	0-12	24/DC	134 084	-
				0-21	24/50	134 085	-
				0-21	110/50	134 086	-
				0-21	230/50	134 087	-
	1.6	M5	0.06	0-6	24/DC	134 088	-
				0-12	24/50	134 089	-
				0-12	110/50	134 090	-
				0-12	230/50	134 091	-
				0-6	24/DC	134 071	134 103
				0-12	24/50	134 092	134 104
				0-12	110/50	134 093	134 105
				0-12	230/50	134 094	134 106
	2.0	G1/8	0.11	0-4.5	24/DC	134 095	134 107
				0-8	24/50	134 096	134 108
				0-8	110/50	134 097	134 109
				0-8	230/50	134 098	134 110
	2.4	G1/8	0.13	0-3	24/DC	134 099	134 111
				0-6	24/50	134 100	134 112
				0-6	110/50	134 101	134 113
				0-6	230/50	134 102	134 114
	1.2	sub-base	0.045	0-12	24/DC	134 115	-
				0-21	24/50	134 116	-
				0-21	110/50	134 117	-
				0-21	230/50	134 118	-
1.6	sub-base	0.06	0-6	24/DC	134 119	134 131	
			0-12	24/50	134 120	134 132	
			0-12	110/50	134 121	134 133	
			0-12	230/50	134 122	134 134	
2.0	sub-base	0.11	0-4.5	24/DC	134 123	134 135	
			0-8	24/50	134 124	134 136	
			0-8	110/50	134 125	134 137	
			0-8	230/50	134 126	134 138	
2.4	sub-base	0.13	0-3	24/DC	134 127	-	
			0-6	24/50	134 128	-	
			0-6	110/50	134 129	-	
			0-6	230/50	134 130	-	

¹⁾ Pressure data [bar]: Overpressure with respect to atmospheric pressure

^{*)} previously DIN 43650

Ordering chart

Type 6011 A

Solenoid valve complete in threaded or flanged version with electrical coil connection to DIN EN 175301-803* Form C for cable plug Type 2506

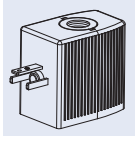

- All valves complete with coil (4 W) and FKM seal material; without cable plug
- Other versions on request.

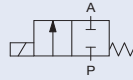

Circuit function	Orifice [mm]	Port connection	Kv value water [m ³ /h]	Pressure range [bar] ¹⁾	Voltage/Frequency [V/Hz]	Item no. Brass body	Item no. Stainless steel body
A	1.6	G1/8	0.06	0-6	24/DC	137 794	137 800
				0-12	230/50	137 795	137 801
	2.0	G1/8	0.11	0-4.5	24/DC	137 796	137 802
				0-8	230/50	137 797	137 803
	2.4	G1/8	0.13	0-3	24/DC	137 798	137 804
				0-6	230/50	137 799	137 805
	1.2	sub-base	0.045	0-12	24/DC	137 806	137 812
				0-21	230/50	137 807	137 813
	1.6	sub-base	0.06	0-6	24/DC	137 808	137 814
				0-12	230/50	137 809	137 815
	2.0	sub-base	0.11	0-4.5	24/DC	137 810	137 816
				0-8	230/50	137 811	137 817

¹⁾ Pressure data [bar]: Overpressure with respect to atmospheric pressure

^{*)} previously DIN 43650

Ordering chart

Type 6011

Solenoid valve complete in ported or flanged version with electrical coil connection Form B (industrial standard) for cable plug Type 2507

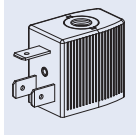

- All valves complete with coil and FKM seal material; without cable plug
- Other versions on request.

Circuit function	Orifice [mm]	Port connection	Kv value water [m ³ /h]	Pressure range [bar] ¹⁾	Voltage/Frequency [V/Hz]	Item no. Brass body	Item no. Stainless steel body
A 	1.2	M5	0.045	0-12	24/DC	163 491	-
				0-21	24/50	163 492	-
				0-21	110/50	163 493	-
				0-21	230/50	163 494	-
	1.6	M5	0.06	0-6	24/DC	163 495	-
				0-12	24/50	163 496	-
				0-12	110/50	163 497	-
				0-12	230/50	163 498	-
		G1/8	0.06	0-6	24/DC	163 499	163 509
				0-12	24/50	163 500	163 510
				0-12	110/50	163 501	163 511
				0-12	230/50	163 502	163 512
	2.0	G1/8	0.11	0-4.5	24/DC	163 503	163 513
				0-8	24/50	163 504	163 514
				0-8	110/50	163 505	163 515
				0-8	230/50	163 506	163 516
	2.4	G1/8	0.13	0-3	24/DC	161 193	163 517
				0-6	24/50	163 507	163 518
				0-6	110/50	163 508	163 519
				0-6	230/50	161 194	163 520
	1.2	sub-base	0.045	0-12	24/DC	163 521	-
				0-21	24/50	163 522	-
				0-21	110/50	163 523	-
				0-21	230/50	163 524	-
1.6	sub-base	0.06	0-6	24/DC	163 525	163 537	
			0-12	24/50	163 526	163 538	
			0-12	110/50	163 527	163 539	
			0-12	230/50	163 528	163 540	
2.0	sub-base	0.11	0-4.5	24/DC	163 529	163 541	
			0-8	24/50	163 530	163 542	
			0-8	110/50	163 531	163 543	
			0-8	230/50	163 532	163 544	
2.4	sub-base	0.13	0-3	24/DC	163 533	-	
			0-6	24/50	163 534	-	
			0-6	110/50	163 535	-	
			0-6	230/50	163 536	-	

¹⁾ Pressure data [bar]: Overpressure with respect to atmospheric pressure

Ordering chart

Type 6011 A

Solenoid valve complete in threaded or flanged version with electrical coil connection Form B (industrial standard) for cable plug Type 2507

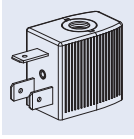

- All valves complete with coil (4 W) and FKM seal material; without cable plug
- Other versions on request.

Circuit function	Orifice [mm]	Port connection	Kv value water [m ³ /h]	Pressure range [bar] ¹⁾	Voltage/Frequency [V/Hz]	Item no. Brass body	Item no. Stainless steel body
A 	1.6	G1/8	0.06	0-6	24/DC	163 545	163 551
				0-12	230/50	163 546	163 552
	2.0	G1/8	0.11	0-4.5	24/DC	163 547	163 553
				0-8	230/50	163 548	163 554
	2.4	G1/8	0.13	0-3	24/DC	163 549	163 555
				0-6	230/50	163 550	163 556
	1.2	sub-base	0.045	0-12	24/DC	163 557	163 563
				0-21	230/50	163 558	163 564
	1.6	sub-base	0.06	0-6	24/DC	163 559	163 565
				0-12	230/50	163 560	163 566
	2.0	sub-base	0.11	0-4.5	24/DC	163 561	163 567
				0-8	230/50	163 562	163 568

¹⁾ Pressure data [bar]: Overpressure with respect to atmospheric pressure

Ordering chart for accessories

Manifolds

Material	No. of valves	Item no.
Aluminium anodized	1	005 312
	2	005 355
	3	005 313
	4	005 314
	5	005 315
	6	005 316
	7	005 893
	8	005 166
	9	005 241
	10	005 819
	11	005 242
	12	005 222

Accessories for manifolds

Accessory	Features	Item no.
Blanking plug	with seal ring, G1/8	005 041
Cover plate	for unused valves	005 100

Cable plug type 2506 to DIN EN 175301-803* form C

	Circuitry	Voltage	Item no.
	None (standard)	0 - 250 V AC/DC	008 353
	with LED	12 - 24 V AC/DC	008 402
	with LED and varistor	12 - 24 V AC/DC	008 408
	with rectifier, LED and varistor	12 - 24 V AC/DC	008 354

- Supplied with cable plug: flat seal and fixing screw.
- Other versions of cable plug with circuitry to DIN EN 175301-803* Form C (see Datasheet Type 2506).

^{*)} previously DIN 43650

Cable plug type 2507 Form B (industrial standard)

	Circuitry	Voltage	Item no.
	None (standard)	2 - 250 V AC/DC	423 845
	with LED	24 V AC/DC	423 849
	with LED and freewheeling diode	12 - 24 V DC	423 851
	with rectifier, LED and varistor	12 - 24 V AC/DC	423 853

- Supplied with cable plug: flat seal and fixing screw.
- Other versions of cable plug with circuitry Form B (industrial standard) (see Datasheet Type 2507).

To find your nearest Burkert facility, click on the orange box →

www.burkert.com

In case of special application conditions,
please consult for advice.

Subject to alterations.
© Christian Bürkert GmbH & Co. KG

0902/6_EU-en_00891723